

ASSEMBLY MANUAL

JUMP KING

3.7 meter / 12 feet

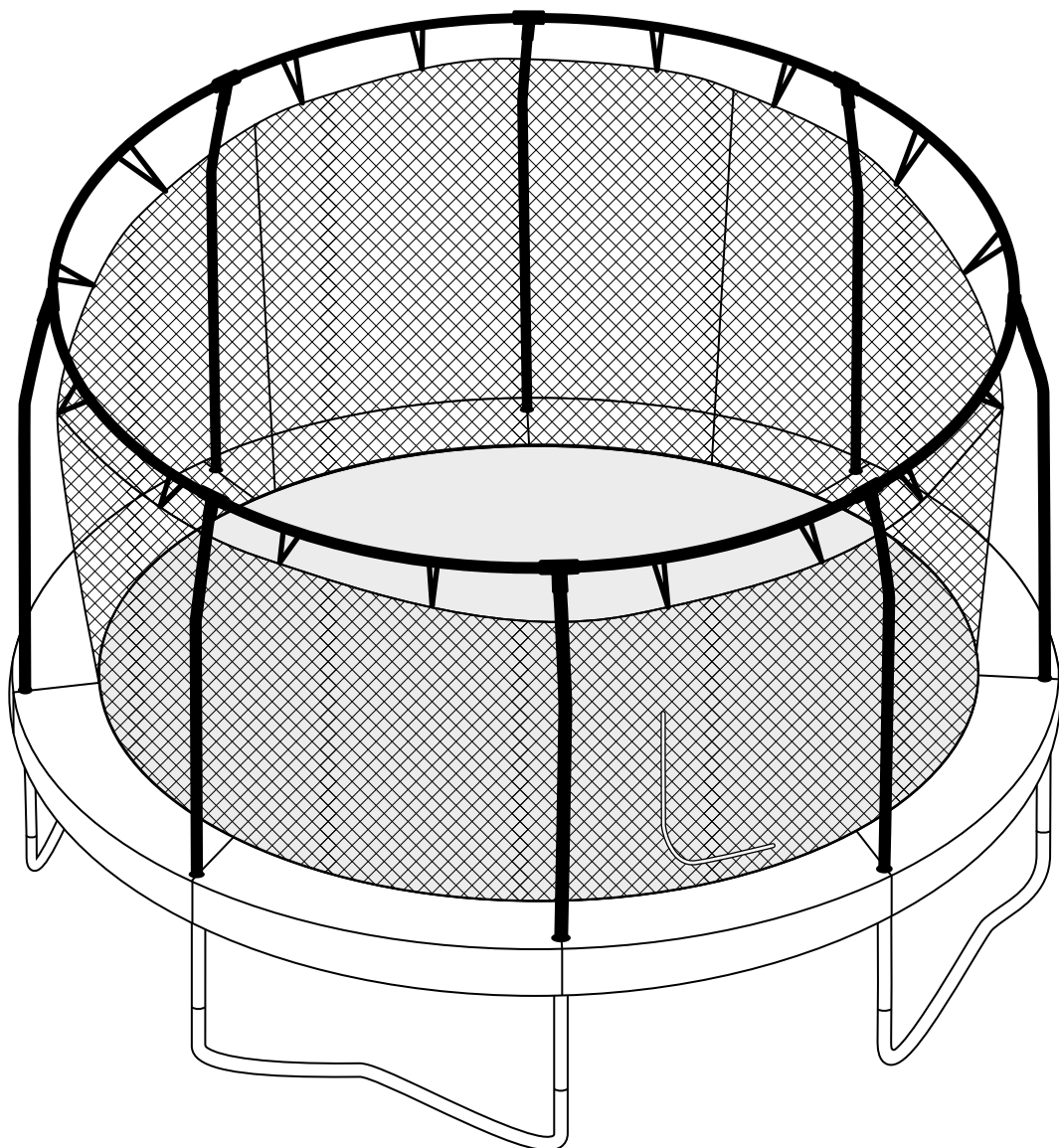

Important information

To reduce the risk of injury, please read and follow the precautions and instructions in this manual before assembling and using the trampoline.

1. The owner and supervisors of the trampoline are responsible to make sure all the users are aware of practices specified in this manual.
2. Place the trampoline on a level surface before use.
3. The trampoline must be placed on lawn, woodchips, sand or other cushioning materials.
4. Adequate overhead clearance is essential. A minimum of 7.3 m (24 ft) from ground level is recommended. Provide clearance for wires, tree limbs, and other possible hazards.
5. Maintain a free space of minimum 25 cm (or 1 meter if the enclosure is not mounted) on all sides of the trampoline. This area should not include concrete, asphalt, brick, or other hard surfaces as these can cause serious injuries.
6. Lateral clearance is essential. Place the trampoline away from walls, structures, fences, and other play areas. Maintain a clear space on sides of the trampoline.
7. Use the trampoline in a well lighted area. Artificial illumination may be required for indoor or shady areas.
8. Secure the trampoline against unauthorized and unsupervised use. If an access ladder is used, it should be removed when the trampoline is not in use.
9. Inspect the trampoline and enclosure before each use, and replace any worn, defective, or missing parts. Make sure the netting, enclosure tubes, and foam sleeves are correctly positioned.
10. Remove any obstructions from beneath the trampoline.
11. The trampoline is designed for users weighing 140 kg or less.
12. Do not allow more than one person on the trampoline. Use by more than one person at the same time can result in serious injury.
13. Misuse and abuse of the trampoline is dangerous and can cause serious injuries.
14. Use the trampoline only with mature, knowledgeable supervision.
15. Climb onto and off the trampoline. Do not jump onto it or off it. Do not use the trampoline as a springboard to other objects.
16. Injury may result from encountering the frame or falling through the springs while getting onto or off the trampoline or while jumping. Stay in the center of the bed when jumping.
17. Do not use the trampoline without the frame pad securely in place to cover the frame. The frame pad is not designed or intended to support the weight of the user. Do not step or jump directly onto the frame pad.
18. The trampoline is a rebounding device that propels the user to unaccustomed heights and into a variety of body movements. Rebounding off the trampoline, striking the frame or springs, or improperly landing on the bed may cause injury.
19. Do not use the trampoline while under the influence of alcohol or drugs. These substances impair reaction time, judgement, and physical coordination.
20. Do not jump on the trampoline while holding an object, particularly one that is sharp or breakable. Remove any eyewear before entering trampoline.
21. Bounce only when the surface of the bed is dry. Wind or air movement should be calm to gentle. The trampoline must not be used in gusty or severe winds.
22. Do not attach anything to the netting that is not a manufacturer approved accessory or part of the enclosure.
23. Wear clothing free of drawstrings, hooks, loops, or anything that could get caught in the netting.
24. Enter and exit the trampoline enclosure only at the door designed for that purpose.
25. Do not attempt to crawl under the netting.
26. Do not attempt to jump over the netting.
27. Do not intentionally rebound off the netting.
28. Keep all flames and heat sources away from the product.

For Sikkerhetstips på norsk: www.jumpking.no

För Säkerhetstips på svenska: www.jumpking.se

For Sikkerhedstips i dansk: www.jumpkingtrampolines.dk

Turvallisuussystä vinkkejä suomeksi: www.jumpking.fi

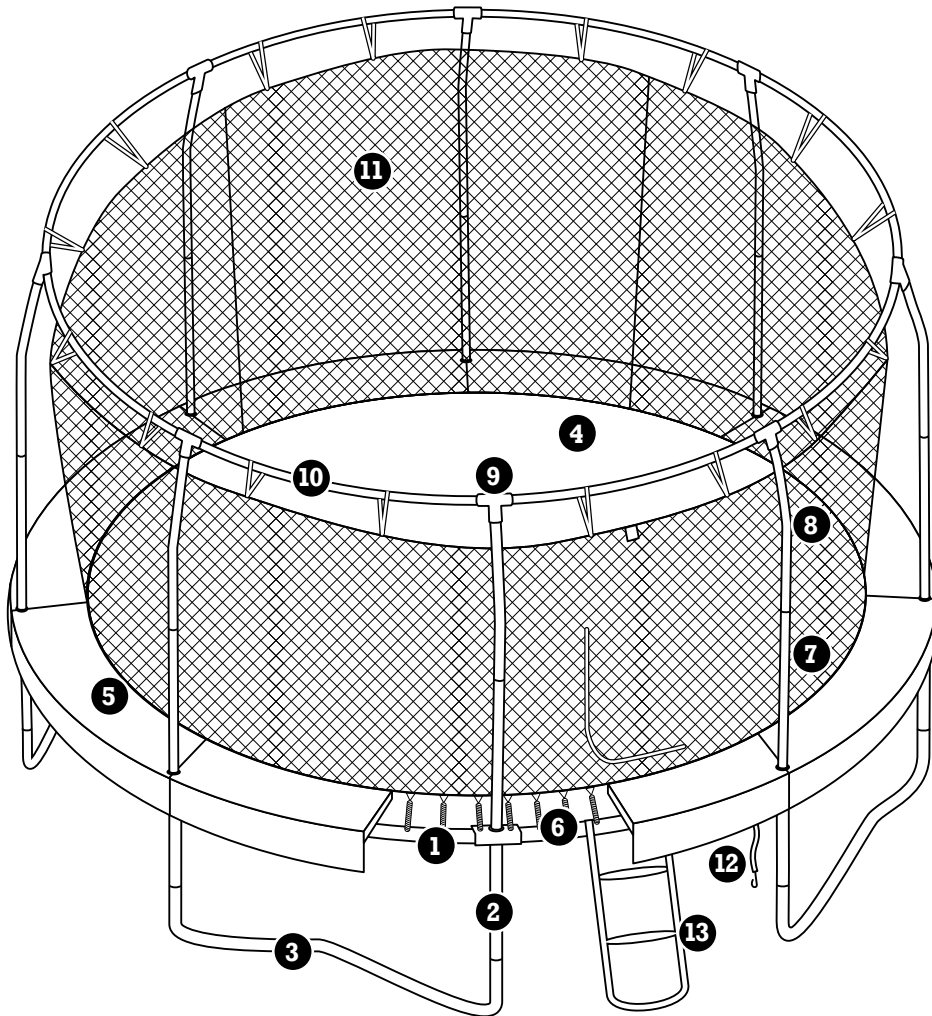

Key no.	Description	Qty
1	Trampoline Top Pipe	8
2	Straight Leg	8
3	W-Leg	4
4	Bed with V-ring	1
5	Frame Pad	1
6	Spring 8,5" (22 cm)	96
7	Enclosure Straight Foam Tube	8
8	Enclosure Top Curved Foam Tube	8
9	Enclosure T-Connector	8
10	Enclosure Top Foam Tube	8
11	Safety Net	1
12	Frame Pad Strap	16
13	Ladder	1
14	Self-tapping Screw	16
15	Cord	8
16	Spring Pulling Tool	1
17	Cap (if the Enclosure is not mounted)	8

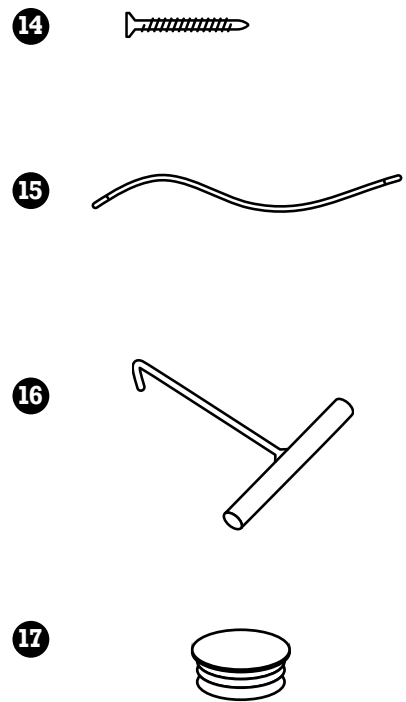

1

Watch Video



jumpking.wistia.com/medias/cr4svo1wuj

4x

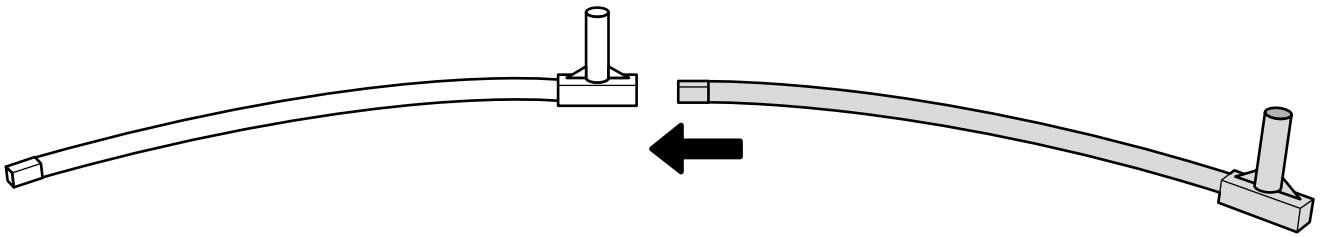

2

4x

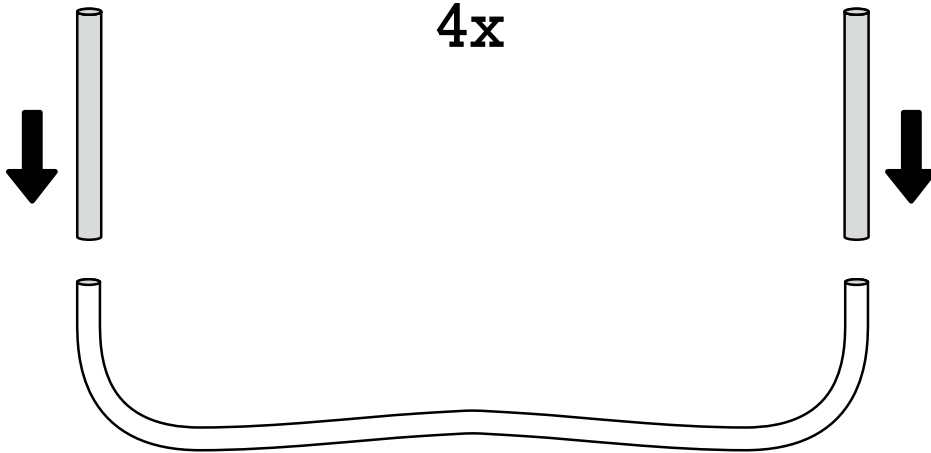

3

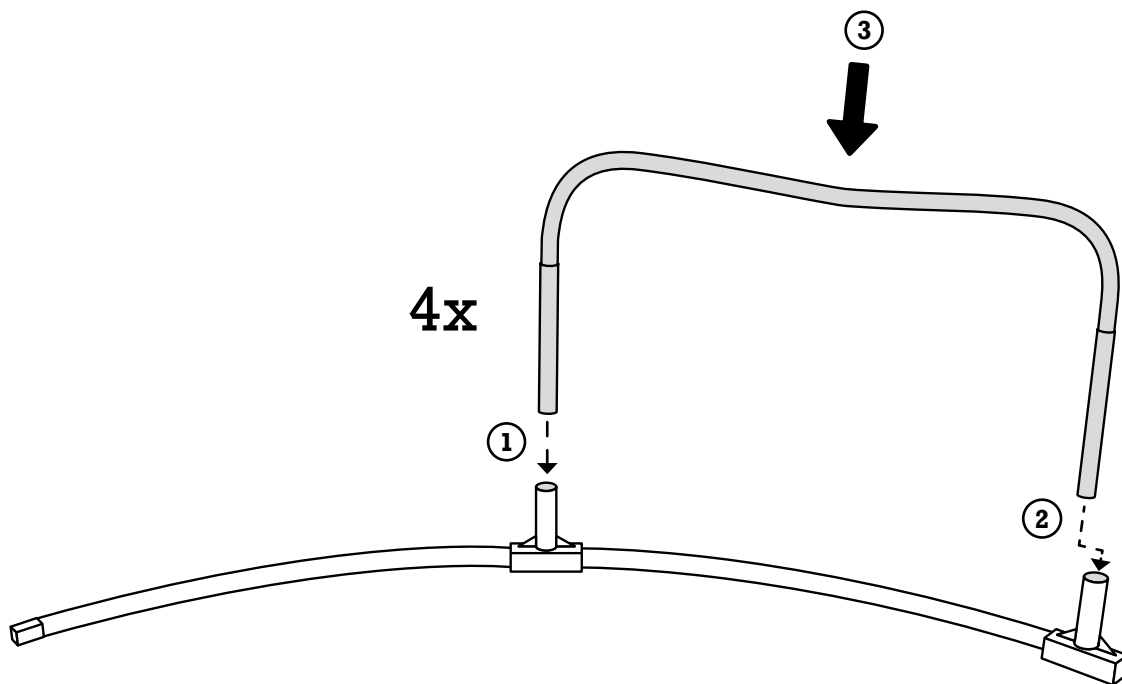

4

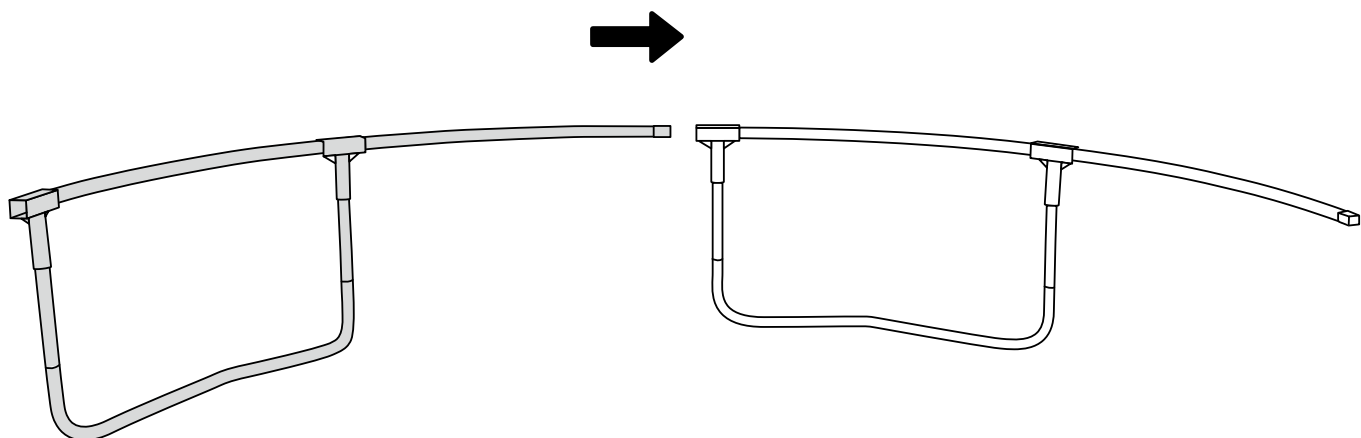

5

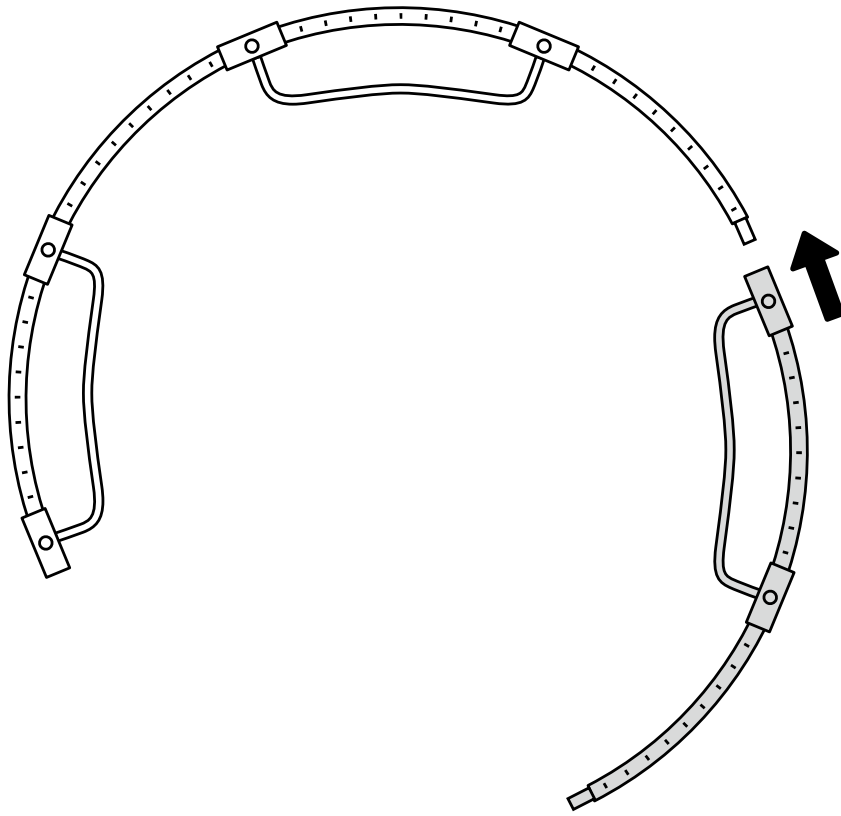

6

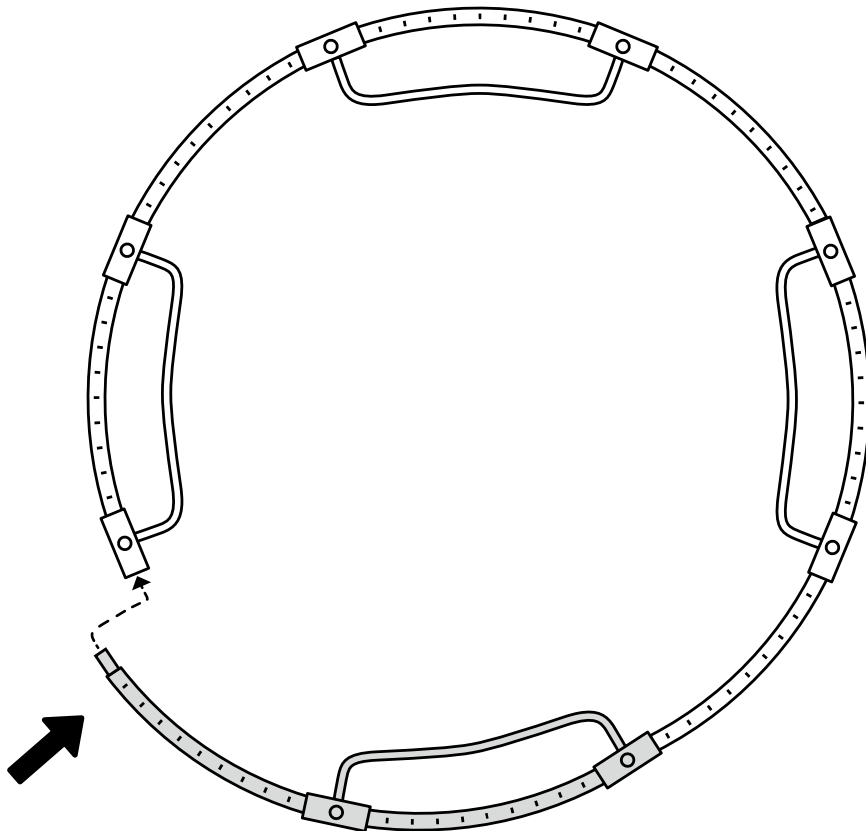

Watch Video



[jumpking.wistia.com/
medias/wfzd9dnd6](https://jumpking.wistia.com/medias/wfzd9dnd6)

7

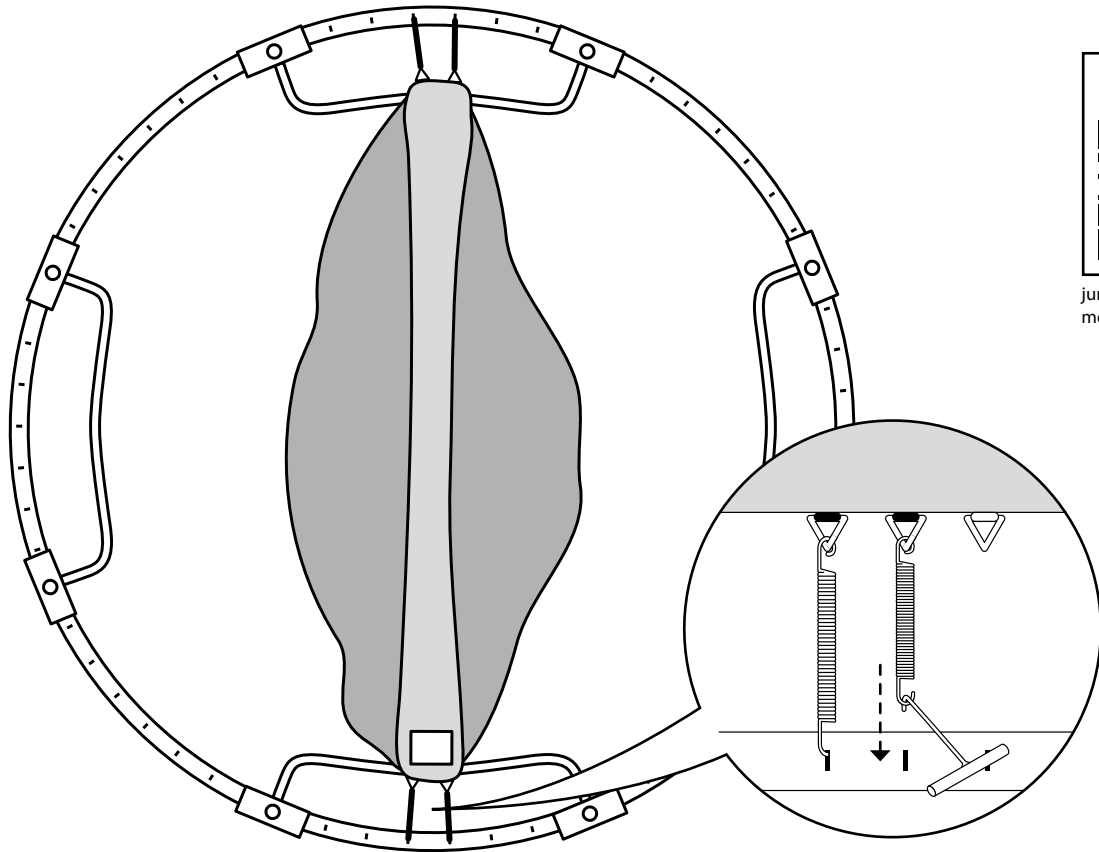

Watch Video

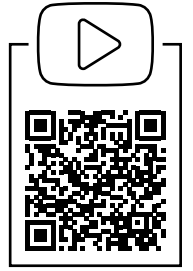

jumping.wistia.com/medias/x1dbv1hurz

8

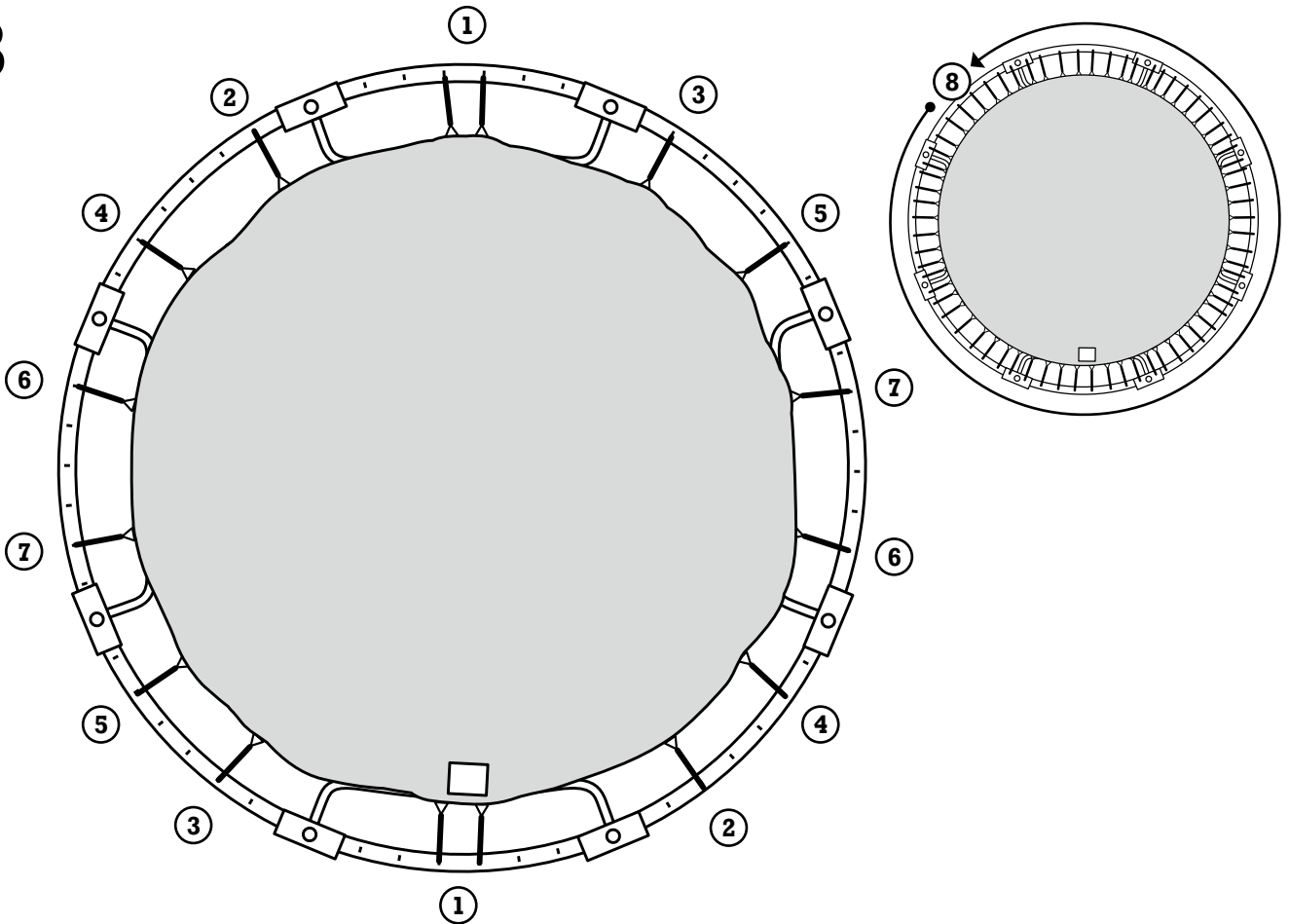

9

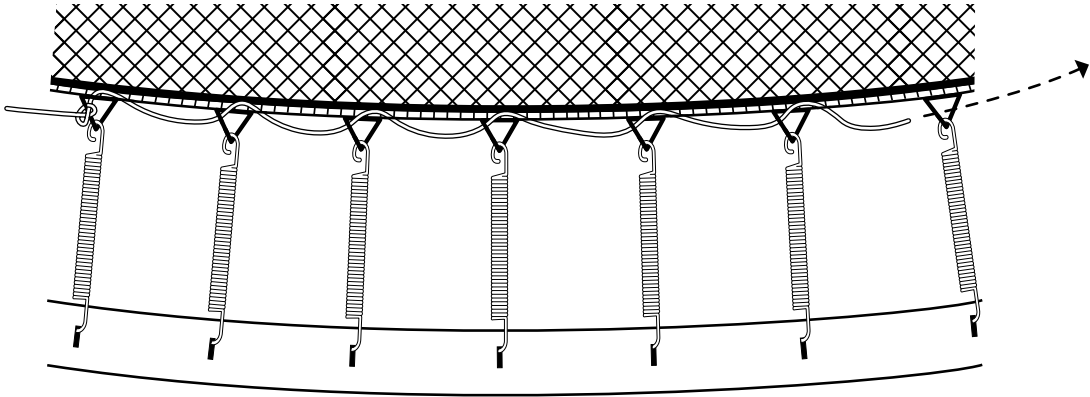
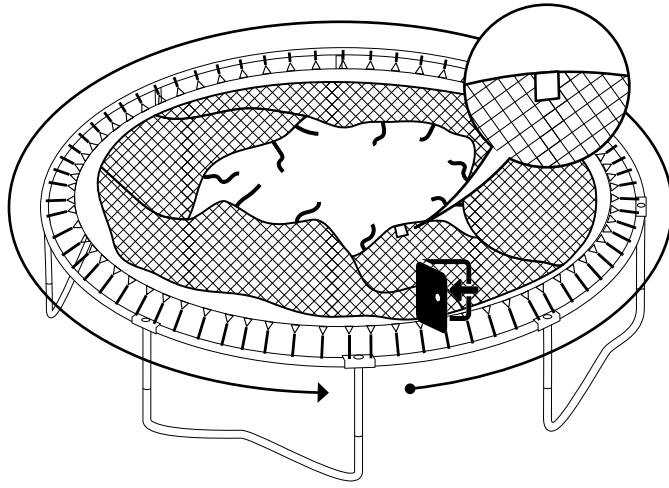

Watch Video



jumpking.wistia.com/medias/d2bch6h4td

10

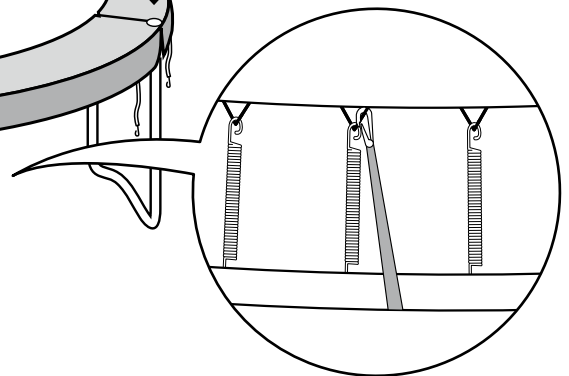
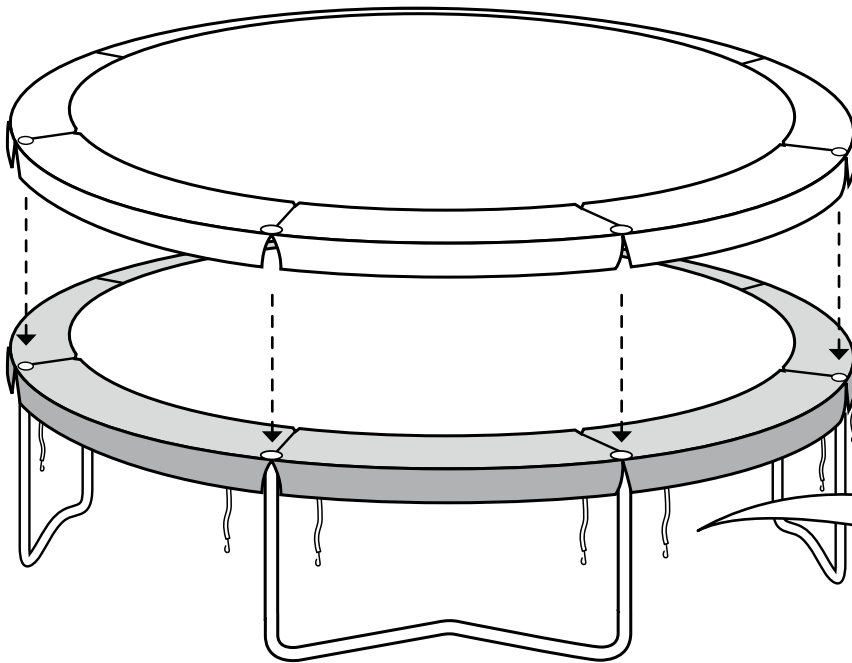

Watch Video



jumpking.wistia.com/medias/ej1qaktla8

11

Watch Video



jumpking.wistia.com/medias/gy93mlfejw

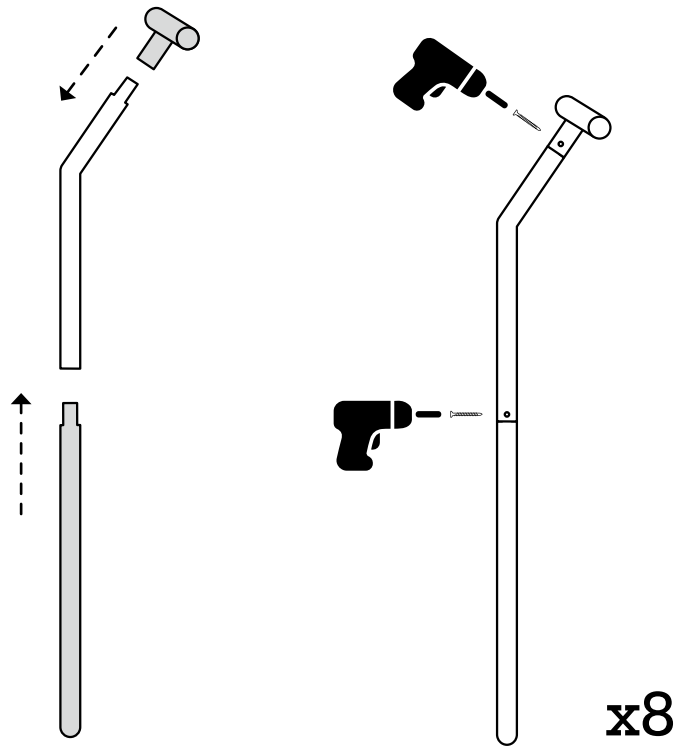

12

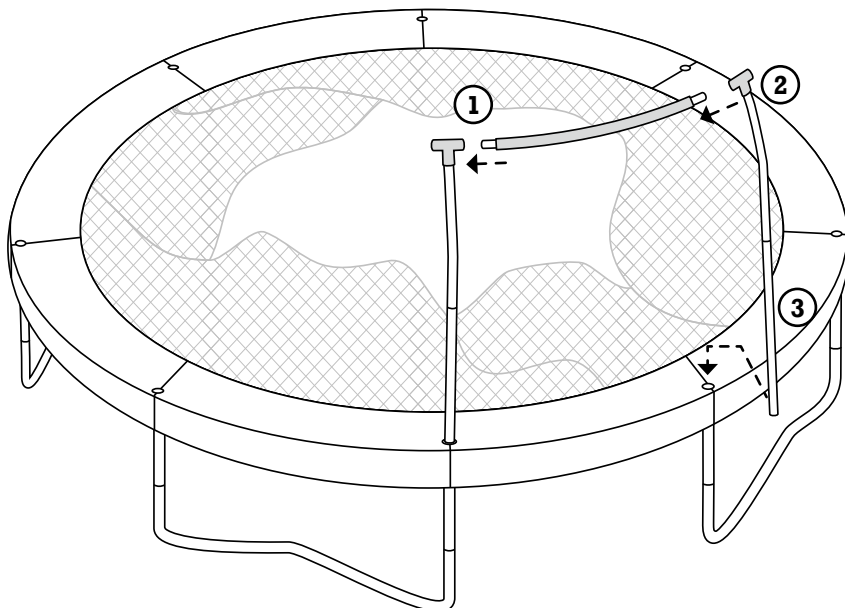
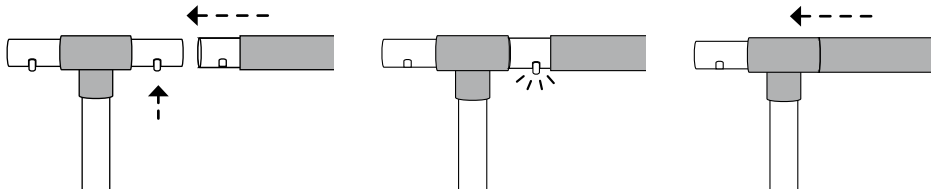

13

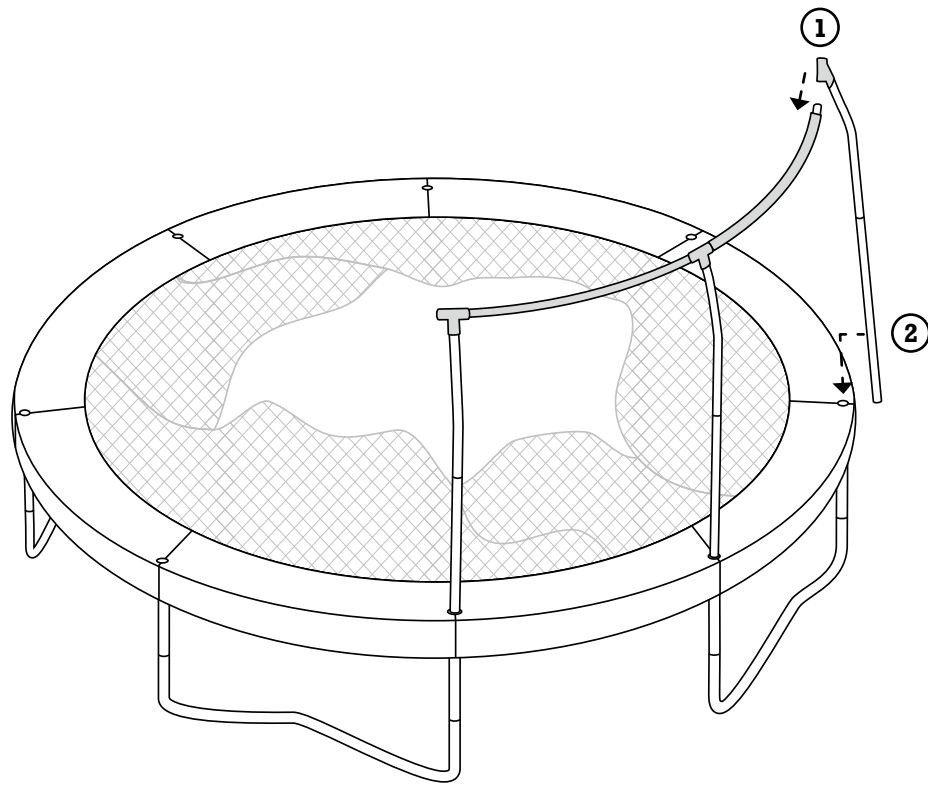

14

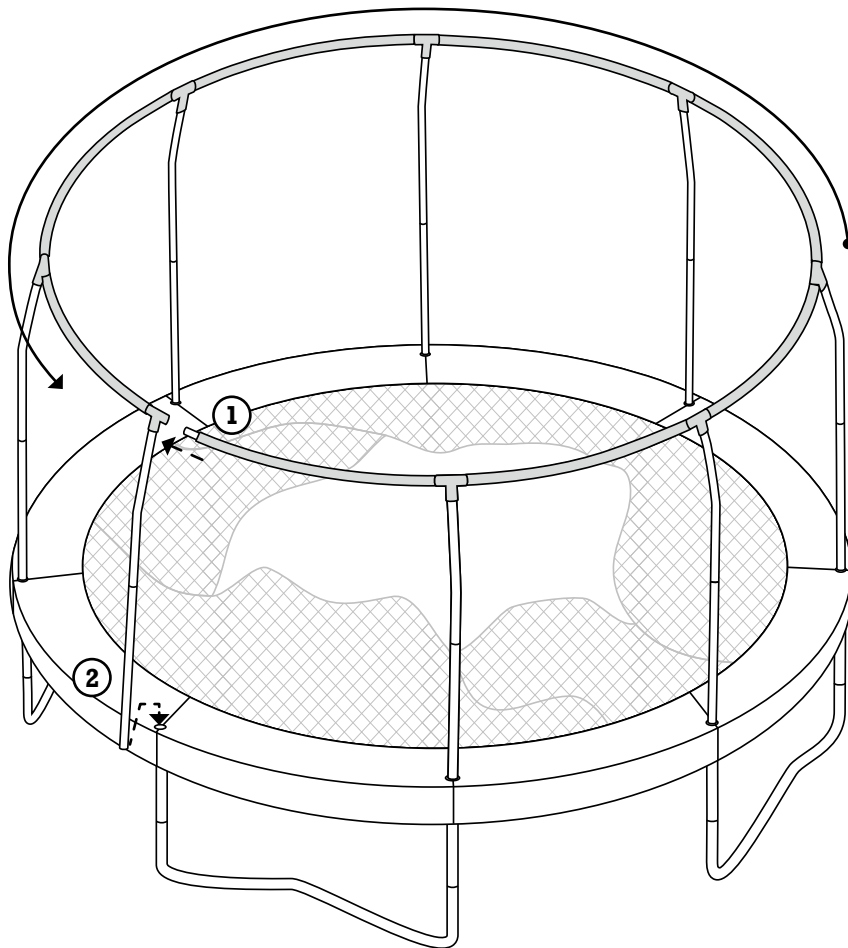

15

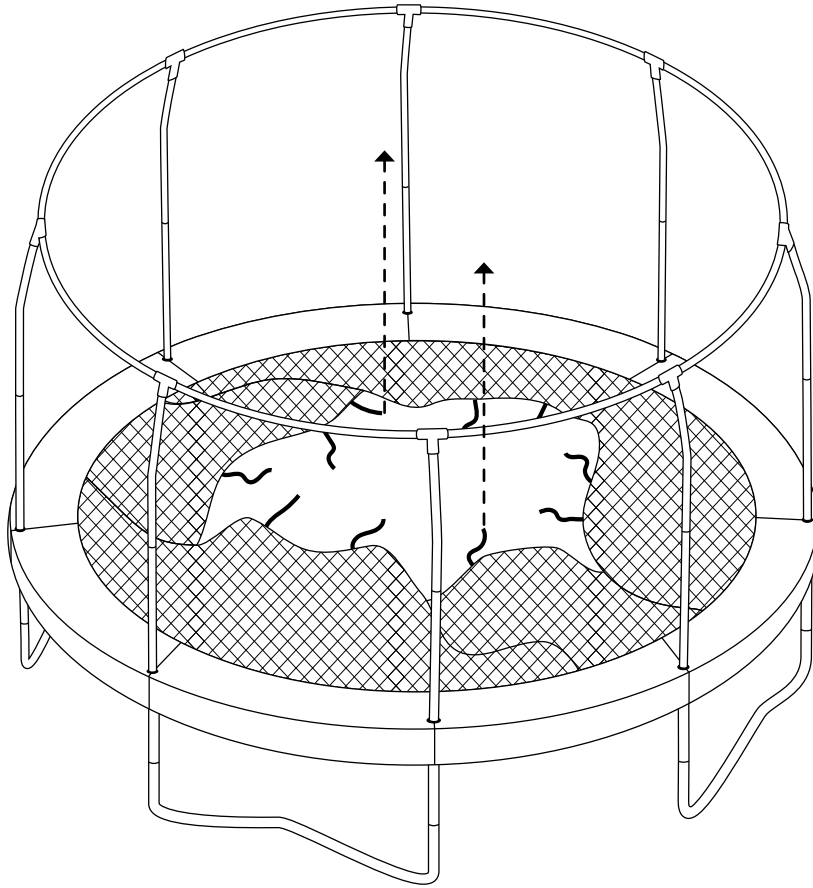

16

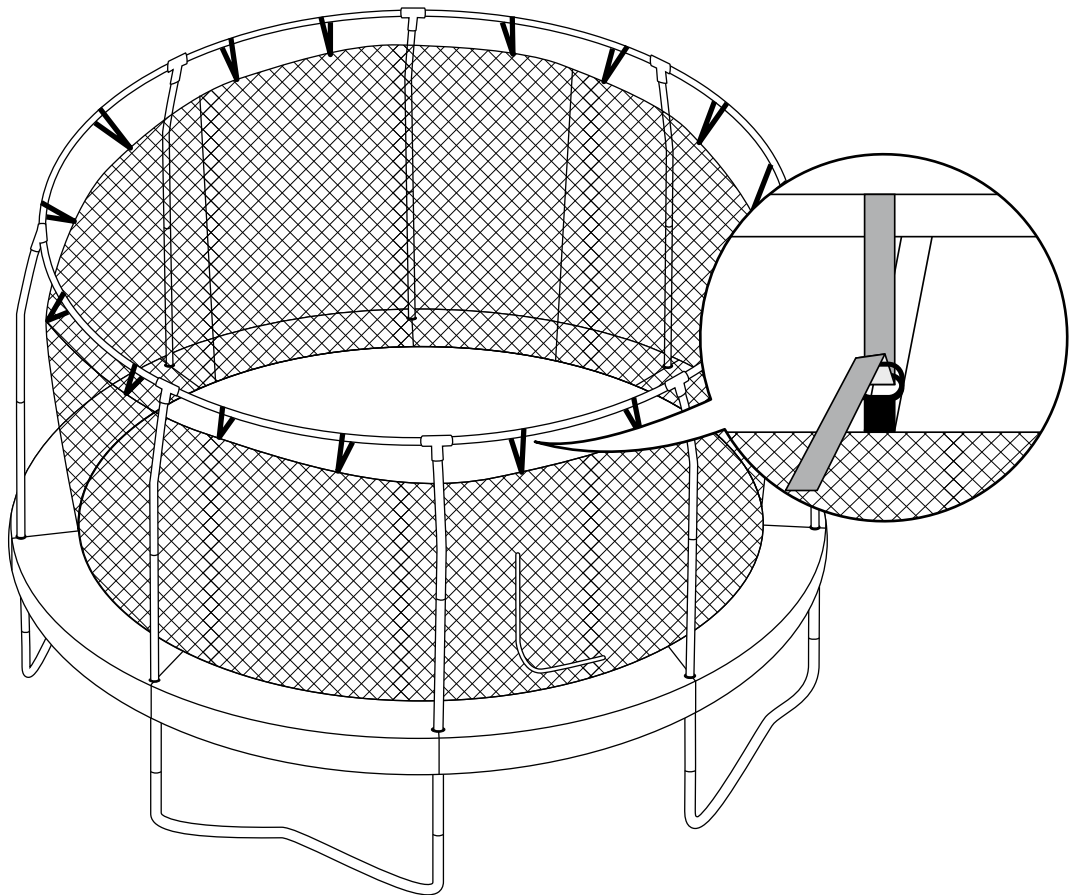



ALWAYS A JUMP AHEAD

Norway

JumpKing AS
Ramstadsletta 10
1363 HØVIK
Norge

+47 67-15 16 17
www.jumpking.no

Sweden

Jumpking Studsmattor AB
Kärrlyckegatan 29B
418 78 Göteborg
Sverige

+46 31-762 25 22
www.jumpking.se

Denmark

Jumpking Studsmattor AB
Kärrlyckegatan 29B
418 78 Gothenburg
Sweden

+46 31-762 25 22
www.jumpkingtrampolines.dk

Finland

Jumpking Studsmattor AB
Kärrlyckegatan 29B
418 78 Gothenburg
Sweden

+46 31-762 25 22
www.jumpking.fi